

Stirling Cooler Probing System

Model: KREUS-SC-PS

- ▶ **Cooled with Free Piston Stirling Cooler System**
- ▶ **Turn on Switch and Cool down to below 60K**
- ▶ **Mechanical Vibration is effectively isolated**

■ Specifications

- ☆ Temp. Range : Below 60K ~ 300K
- ☆ Cooldown Time : 30 min to 60K
- ☆ Sample Size : 15mm x 15mm
- ☆ Probe Stroke : X, Y ±12 mm Z ±6 mm
- ☆ Feed through : 4 Triaxial Connectors
- ☆ Vacuum : ~ 10⁻⁴Pa
- ☆ System Size : □330mm x H700mm



■ Construction

1. **Stirling Cooler**
2. **Probe Vacuum Chamber**
3. **Temperature Control Unit**
4. **4 Probe Manipulators**
5. **CCD Camera & Mono Scope**
6. **LCD Monitor**
7. **System Stand**

■ CryoCooler Specifications

- | | | |
|-------------------------------|-------------------|----------------------|
| * Free Piston Stirling Cooler | Cooling Capacity | : 10W@77K |
| * Power Consumption < 200W | Power Requirement | : 24VDC / 160W |
| * Maintenance Free | Ultimate Temp. | : 35K (with no load) |
| * No Cooling Water Needed | Weight | : 3.1kg |

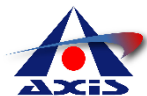

AXIS Corporation

646-2 Sasagi Tsukuba Ibaraki 305-0043 JAPAN
TEL 029-849-2220 FAX 029-849-2221
info@axj.co.jp http://axj.co.jp



Kreuz Design Inc.

2393 Welcher Ave., unit 302
Port Coquitlam, British Columbia V3C 1X6
Tel :+1 604 945 6639; Fax: +1 604 229 6156
e-mail: epistle@kreus.com

Please contact one of our office for sales inquiry

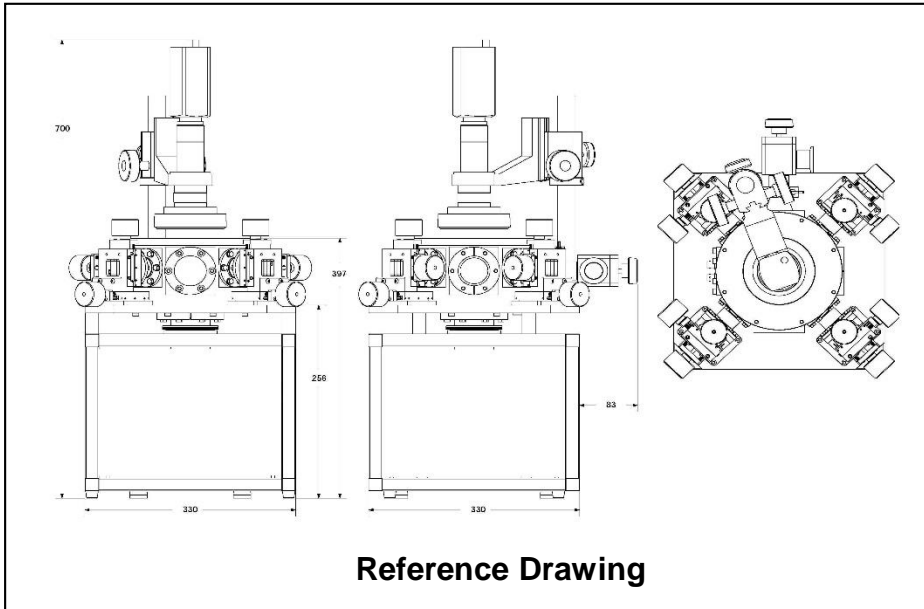

Measured Performance

CryoTel™ CT

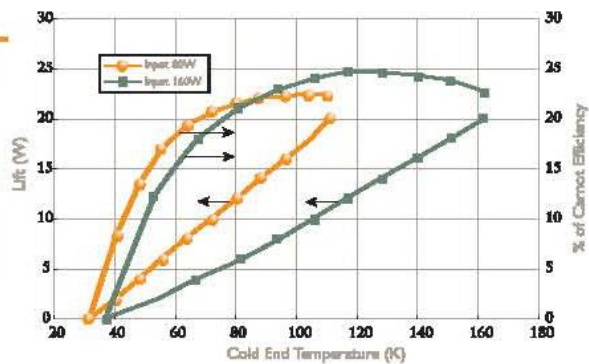

Options

1. Bias Measurement Unit (~100V)
2. Ultra Low Noise Application ($< \pm 1\text{pA}$)
3. High Vacuuming System
4. Convection Vacuum Gauge ($\sim 10^{-4}\text{Torr}$)
5. Probe Side Monitor (CCD Microscope & Monitor)
6. Tungsten Probe Needle
7. Gold Plated BeCu Probe Needle
8. Tungsten Ultra Thin Probe Needle
9. Soft Contact Dumper
10. BNC/Triaial/SMA Adofter Connectors

* Specifications may change without notice